

# RL-5533

## FLYBACK TRANSFORMER

### FOR NATIONAL SEMICONDUCTOR

#### DESCRIPTION

- Flyback Transformer
- LM-258X-T6

#### ENVIRONMENTAL DATA

- Storage temperature range: -55°C to +130°C
- Operating temperature range: -40°C to +130°C

#### PACKAGING INFORMATION

- Packaging information: pg. 495

#### FEATURES & APPLICATIONS

- Compact through-hole transformer
- Flyback topology power supplies

Verify operation with sample in actual circuit. Order samples at [www.rencousa.com](http://www.rencousa.com).

#### MECHANICAL DIMENSIONS

U.S. Standard (mm)

PART NUMBER	A (MAX.)	B	C (MAX.)	D (MAX.)	E (MIN.)	F (TYP.)	G
RL-5533	0.93 (23.62)	0.515 (13.08)	0.86 (21.84)	0.66 (16.76)	0.175 (4.44)	0.20 (5.08)	0.15 (3.81)

PART NUMBER	PART WEIGHT
RL-5533	12.0g (0.42oz)

#### TEST MEASUREMENTS:

1. L (1-2) = 66  $\mu$ H  $\pm$  10% AT 0.1 VRMS 10 kHz
2. Le (1-2) = 1.4  $\mu$ H MAX AT 10 kHz WITH (5-6) (7-8) SHORTED

3. RDC (1-2) = 0.050 $\Omega$   $\pm$  15%  
RDC (5-6) = 0.112 $\Omega$   $\pm$  15%  
RDC (7-8) = 0.112 $\Omega$   $\pm$  15%
4. HIPOT: 600 VRMS BETWEEN (1-2) AND (5-6) (7-8)

FRONT VIEW

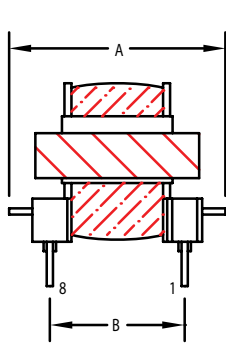

SIDE VIEW

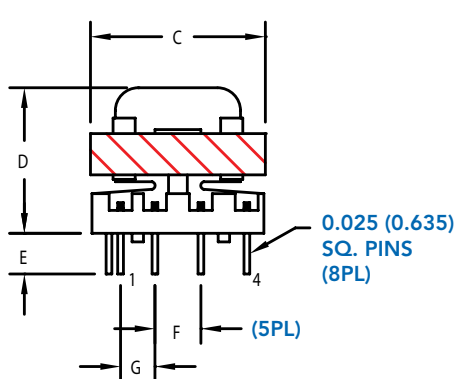

SCHEMATIC

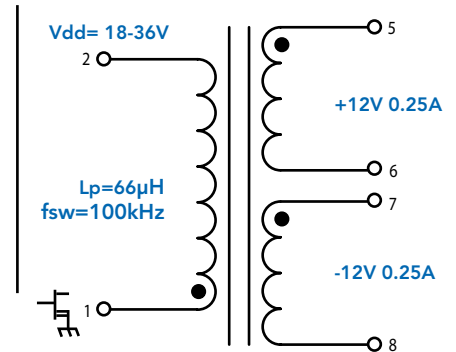

**RENCO ELECTRONICS INC.**

595 International Place, Rockledge, FL 32955-4200 USA • [www.rencousa.com](http://www.rencousa.com) • ISO 9001 Certified  
Toll Free Engineering Hot Line: 800.645.5828 • P: 321.637.1000 • F: 321.637.1600

